



Special Purpose Strain Gages - High-Temperature Weldable Strain Gages

FEATURES

- High temperature installations using simple attachment techniques
- Ceramic bonded wire gage performance in a weldable gage
- Superior performance of bonded gages
- Improved fatigue life for dynamic applications

Vishay Micro-Measurements high-temperature weldable strain gages are free-filament wire strain gages pre-bonded to shim stock using flame sprayed alumina. The gages can be welded to the test structure using a capacitive discharge spot welder (such as Vishay Micro-Measurements Model 700), permitting easy installation in the field, especially on large structures. High-temperature weldable strain gages are excellent in applications where protection against moisture is not required. The fatigue resistance of this bonded wire strain gage makes it the best choice for dynamic, impact or vibratory strain measurements to

1800°F (980°C). While designed primarily for dynamic measurement applications, the active dummy method of temperature compensation can be used when static strain measurements are made.

High-temperature weldable strain gages are available with grids of Nichrome V or Pt8W alloys. They can be ordered with either of two types of preattached high-temperature insulated cable.

GAGES WITH M-SERIES LEADWIRES

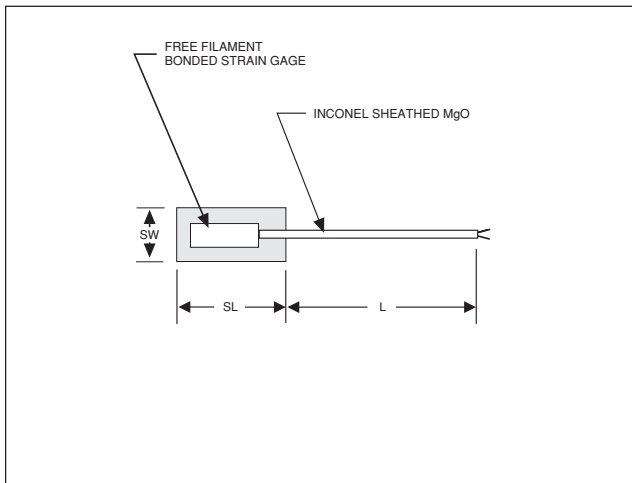

Complete assembly consists of a free-filament gage bonded to a shim with an integral high-temperature cable with chromel/alumel wires. The mineral insulated, two-conductor cable with an Inconel metal jacket is rated to 1800°F (980°C) and offers excellent protective in harsh environments. While the ends are sealed to avoid moisture absorption during shipping or storage, care should be taken when using M-Series cables to ensure that the mineral insulation does not absorb moisture during handling and application.

GAGES WITH F-SERIES LEADWIRES

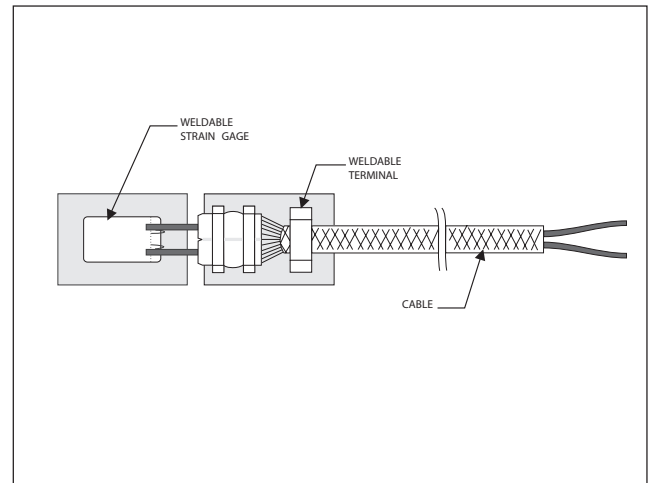

Complete assembly consists of a free-filament gage bonded to a shim, a weldable transition terminal and a high temperature cable with chromel/alumel wire. A fiberglass-insulated braided, two-conductor cable assembly is attached at the gage end through alumina insulators strap-welded to the terminal shim, providing a firm anchor for the cable at the gage end. The cable conductors are threaded through lengthwise holes in the alumina insulators and bonded to the insulators with high strength ceramic cement to prevent wire movement at the gage - cable weld junction. The fiberglass cable is rated to 1200°F (650°C) and is used where fraying due to vibration is not a concern. F-Series cables are more flexible than M-Series cables.

High-Temperature Weldable Strain Gages



Vishay Micro-Measurements

Special Purpose Strain Gages - High-Temperature Weldable Strain Gages

DESIGNATION	NOMINAL RESISTANCE IN OHMS	NOMINAL GAGE FACTOR	SENSOR ALLOY	SENSOR GAGE LENGTH	MAXIMUM TEMP. IN DEG.F	LEADWIRE	SHIM LENGTH S.L. (IN)	SHIM WIDTH S.W. (IN.)	LEAD TERMINAL
LZN-NC-W250G-120/2F	120	2.0	NiChrome V	1/4"	1200 °F	Chromel-Alumel	0.50	0.30	Yes
LZN-NC-W250G-120/2M	120	2.0	NiChrome V	1/4"	1600 °F	Chromel-Alumel	0.50	0.30	None
LZE-NC-W250G-120/2F	120	4.0	Pt8W	1/4"	1200 °F	Chromel-Alumel	0.50	0.30	Yes
LZE-NC-W250G-120/2M	120	4.0	Pt8W	1/4"	1800 °F	Chromel-Alumel	0.50	0.30	None